

HYDROTITE

HYDROPHILIC CHLOROPRENE RUBBER WATERSTOP



PRODUCT DESCRIPTION

Hydrotite is the brand name for a state of the art hydrophilic waterstop with unmatched durability and water sealing capacity. **Hydrotite** expands as it absorbs water and fills up concrete joint gaps conforming to the gap variation, ensuring excellent sealing. **Hydrotite** is based on the technology of hydrophilic, a material which expands in a controlled fashion by approximately eight times by volume in the presence of moisture to create a pressure seal within the joint, when properly installed. **Hydrotite** is capable of sealing heads of water up to 50 metres and is used extensively throughout the construction industry to seal horizontal and vertical construction joints for poured in-situ concrete.



Hydrotite consists of a unique combination of expanding hydrophilic materials and non-expanding chloroprene rubber, co-extruded together to form a single strip. The expanding section is blue with the non-expanding section being black. The co-extruded design means that the expansion is directed across the joint for maximum sealing performance. This expansion creates an effective compression seal within the joint, preventing the egress of water through it. Upon expansion, **Hydrotite** turns from a dark blue colour to a light blue colour, so that a visual inspection of the Hydrotite can be made and so the contractor can see if the **Hydrotite** has pre-expanded.

Contractors require an economical waterstop that is easy to install and needs to perform over a long period of time maintaining joint integrity. Recognised world-wide, **Hydrotite** has a proven track record as a high quality and cost-effective solution as a waterstop for water retaining or water excluding needs.

Hydrotite is treated with a delay coating to prevent it from absorbing water from the wet concrete of the second pour, and to also help stop any premature expansion should the joint become ponded with water, prior to the second pour being placed, and to stop any premature expansion taking place before curing of the concrete.

Hydrotite, as with any hydrophilic waterstop, will return to its original size if there is no more water or moisture present. **Hydrotite** will then re-expand when water or moisture is reintroduced to the joint. Some initial leakage may occur before **Hydrotite** re-expands fully. Repeated wet and dry cycling of this nature does not affect the functioning of **Hydrotite**.

The standard dimension and shape of CJ-0725-3K-AD-EX is as per fig. 1

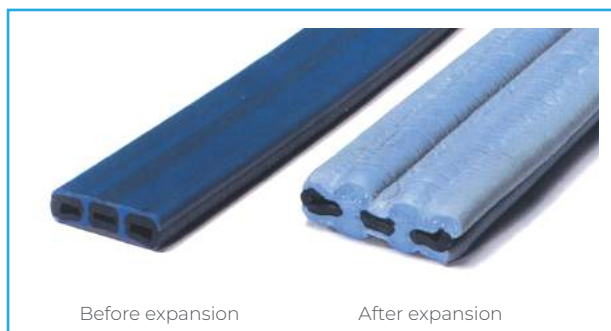
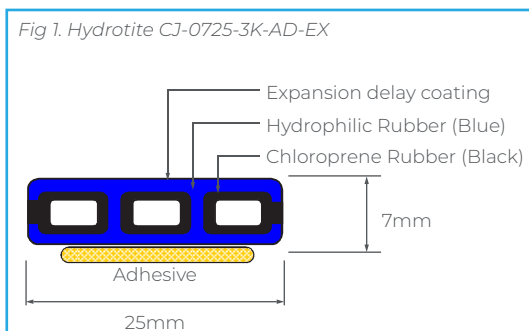



ADVANTAGES

- Easy to handle and install
- Excellent adhesion to concrete surfaces
- Outstanding physical properties
- Profiles with self-adhesive backing allow for simple and fast installation processes
- Co-extruded design means expansion is directed across the joint for maximum seal
- Capable of sealing heads of water up to 50 metres
- Unaffected by repeated wet and dry cycles
- No site welding is required for joining processes
- Has a delay coating to help prevent premature expansion
- Changes colour as a visual alert to let you know it has expanded
- No need for special intersections, joining is by simple butt joints
- Can be applied to rough surfaces using Leakmaster gun grade waterstop
- Can be joined to traditional PVC waterstop. Refer **CORKJOINT** for further information.
- No compaction or displacement problems
- Non-toxic and non-hazardous. NSF certified.
- No need for split forming



AREAS OF APPLICATION

Hydrotite is to be used where watertight integrity is the prime issue. Typical applications where there is a need to achieve a water seal include: -

- | | | |
|-----------------------------|-------------------|---------------------|
| ● Sewerage Treatment Plants | ● Swimming Pools | ● Basements |
| ● Water Treatment Plants | ● Tunnels | ● Pits |
| ● Reservoirs | ● Subway Stations | ● Pipe Penetrations |
| ● Water Tanks | | |

Note: The product's design and performance, its intended use, installation and final confirmation and approval for use, must be provided by the project's Design Engineer and Project Manager.

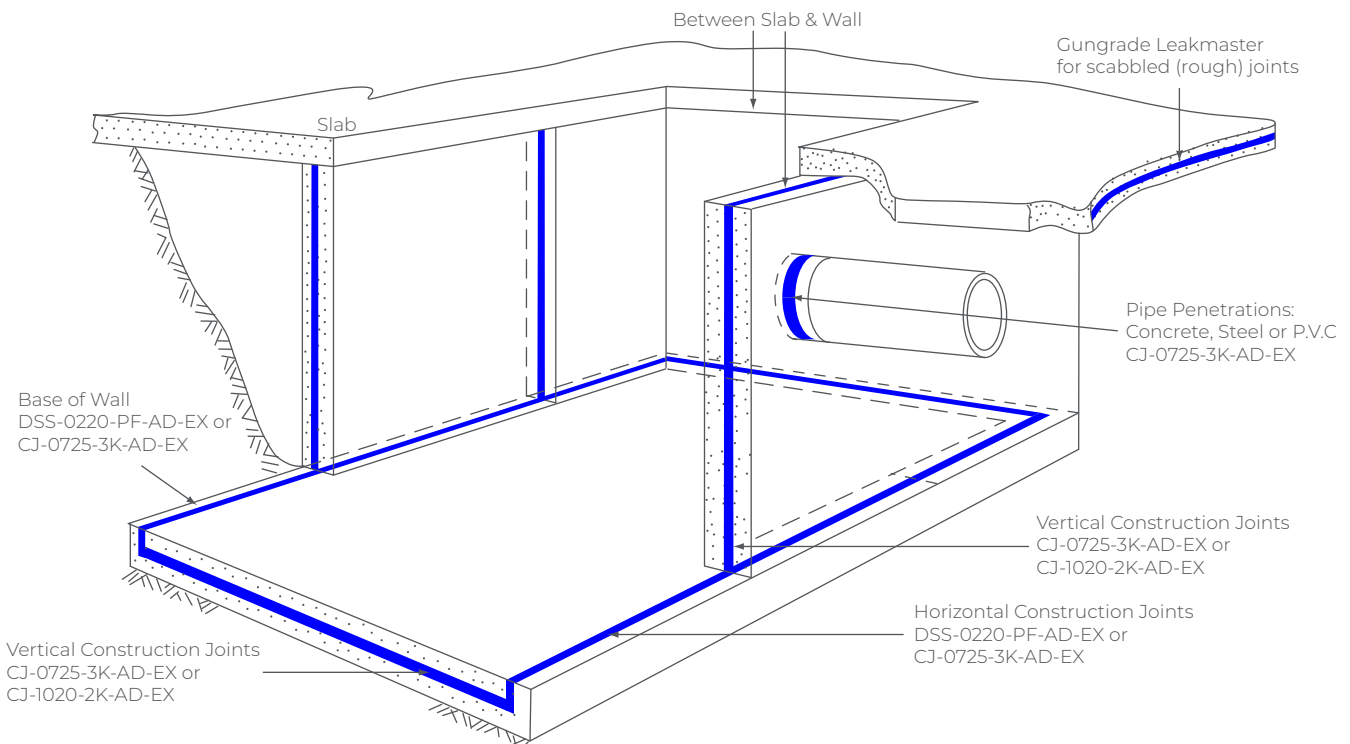

*Note: Contact **CORKJOINT** for application and product type verification.*





PROFILE SELECTION

Shown below is a guideline of the types of **Hydrotite** profiles that are available for use in construction joints in various projects.

Note : Contact **CORKJOINT** for application and product type verification. Joint details should be verified and approved by the Consulting Engineer who should satisfy himself of the suitability of the product for its intended use.

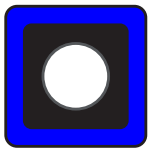

CJ-3030-M



CJ-2020-M



RSS-TYPE



DSS-0220-PF-AD-EX



CJ-1020-2K-AD-EX



CJ-0725-3K-AD-EX



CJ-1030-4M

- **Vertical construction joints**
CJ-0725-3K-AD-EX, CJ-1020-2K-AD-EX, CJ1030-4M
- **Horizontal construction joints**
DSS-0220-PF-AD-EX, CJ-0725-3K-AD-EX, CJ-1020-2K-AD-EX, Leakmaster
- **Joint and Leak repairs**
RSS RODS Various sizes
- **Pipe penetrations**
DSS-0220-PF-AD-EX, CJ-0725-3K-AD-EX, Leakmaster
- **Thru tie holes**
RSS RODS, RSS2519D, RSS2014D



TYPICAL APPLICATIONS

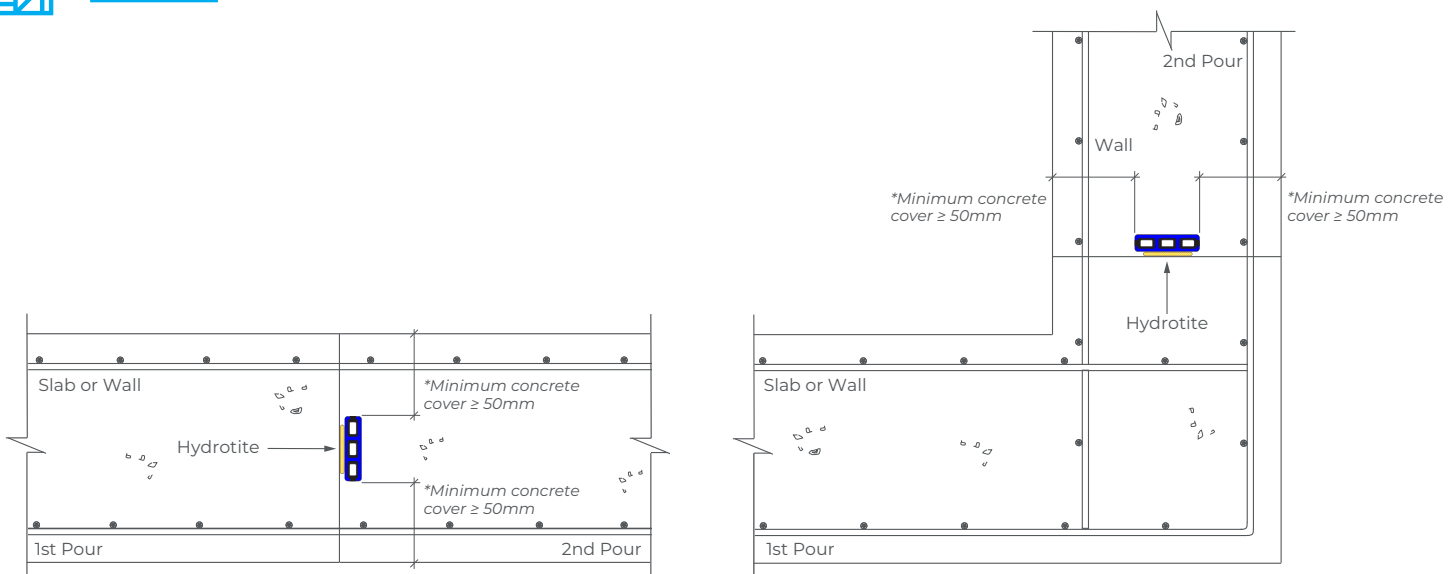

SLAB ON GROUND OR WALL

SLAB TO KICKER IN WALL

Note : Refer to above minimum concrete cover requirements for CJ-0725-3K-AD-EX. Bigger profiles may require a greater concrete cover and please refer to **CORKJOINT** for further information.



NOTES

Due to expansive forces, **Hydrotite** should be both detailed and installed with a minimum 50mm clear cover to the face of the concrete. Expansion rate can vary in salt and contaminated water. Increase cover when using light weight, low strength concrete. Not for use where excessive shrinkage of the concrete may occur at the joint faces. Do not stretch the **Hydrotite** during installation. Not for use in movement (expansion, isolation and contraction) joints.





PHYSICAL PROPERTIES

ITEM	UNIT	HYDROPHILIC RUBBER		NON-HYDROPHILIC RUBBER		TEST METHOD
		Spec.	Result	Spec.	Result	
Hardness Shore A	-	50 ± 5	53	50 ± 5	52	JIS K 6253
Tensile Strength	MPa	2.9 min.	3.4	8.8 min.	11	JIS K 6251
Elongation	%	600 min.	695	400 min.	460	JIS K 6251

- Note:
- The test specimens are taken from pressed sheet made of the same compound as production.
 - The above physical properties are from an in-house laboratory test. Material properties can vary between batches of ± 10%.



EXPANSION RATE PROPERTIES

TEST CONDITION

Test Water : Distilled water
 Water Temp. : 23C+/-2
 Immersion Period : 60 days
 Test Method : In house test

TEST RESULT

SPECIMEN	VOLUME EXPANSION RATE
Hydrophilic portion of product	600 %
CJ-0725-3K with delay coating	250 %

Note: The values shown above are the measured values and not the specific value.



PACKAGING

PROFILE	DIMENSIONS	METRES PER ROLL	METRES PER CARTON
DSS-0220-PF-AD-EX	20mm x 2mm	25	100
CJ-0725-3K-AD-EX	25mm x 7mm	10	40
CJ-1020-2K-AD-EX	20mm x 10mm	10	50
CJ1030-4M	30mm x 10mm	10	40
CJ2020-M	20mm x 20mm	10	30
CJ3030-M	30mm x 30mm	5	10
RSS1208D	12mm diameter	20	40
RSS1610D	16mm diameter	10	20
RSS2014D	20mm diameter	10	20
RSS2519D	25mm diameter	5	10





CHEMICAL RESISTANCE

The influence of pH values of concrete, grouting material and ground water upon the expansion of **Hydrotite** was tested using hydrophilic rubber as below. The specimen was immersed in each solution for seven days and the retention value of tensile strength and elongation were measured. Then, the specimen was removed from each solution and placed in tap water for seven days. The specimen was then compared with specimens that had been expanded in tap water only.

The retention value of both physical properties and expansion was compared with that of specimens tested in tap water. **Hydrotite** keeps the retention values 90% or more in all solutions listed in the table below. In the table, "O" indicates retention value 90% or more.

TYPE OF TEST SOLUTION	CHANGE OF PHYSICAL PROPERTIES AFTER 7 DAYS IMMERSION		RETENTION OF EXPANSION VALUE AFTER 7 DAYS IMMERSION IN TAP WATER FOLLOWING IMMERSION IN SOLUTION
	TENSILE STRENGTH	ELONGATION	
pH 3 aqueous solution	O	O	O
pH 5 aqueous solution	O	O	O
pH 7 (tap water)	-	-	-
pH 9 aqueous solution	O	O	O
pH 11 aqueous solution	O	O	O
Ferrous aqueous solution	O	O	O
Bentonite aqueous solution	O	O	O
Grout aqueous solution	O	O	O



LEAKMASTER

Leakmaster is a water swelling gun grade waterstop with excellent and unique physical properties. It can be used in places where the standard extruded profiles are not suitable in areas such as rough concrete surfaces or as a back-up to these profiles in complex junctions. (Please refer to separate Leakmaster brochure).



WRITTEN SPECIFICATION

Hydrophilic expanding waterstops shall be placed at the joints in the concrete at the locations shown on the drawings in accordance with the requirement of this specification. Waterstops where shown on drawings shall be **Hydrotite** (State profile number required) Hydrophilic Waterstops as supplied by **CORKJOINT**.

The waterstop shall consist of a non-expansive black chloroprene rubber, co-extruded with a blue hydrophilic rubber, which is capable of swelling by approximately eight times by volume. The waterstop shall be treated with a delay coating to prevent premature expansion and be able to change colour upon expansion which acts as a visual alert that the waterstop has started to expand. The waterstop is to be installed strictly in accordance with the manufacturer's recommendations.



HEALTH AND SAFETY INFORMATION

In confined spaces or in still air conditions, the use of a ventilation fan or suitable respirator should be used, and the advice and approval of the Site Safety Supervisor is essential. For further information or advice on health and safety precautions, safe handling, storage and correct disposal of products, please refer to the most recent product Safety Data Sheet (SDS), which is available upon request.





DISCLAIMER

The information and the recommendations relating to the application and end use of this product are given in good faith and are based on the information provided by the manufacturer of the product and/or the Company's current knowledge and experience in connection with the product when properly stored, handled and applied under normal conditions and no liability of final function at the job site is assumed. In practice, the differences in materials, substrates and actual site conditions are such that no warranty in respect of merchantability of, or fitness for, particular purpose, nor any liability arising out of any legal relationship whatsoever, can be inferred either from this information, or from any written and/or oral recommendations, or from any other advice offered by the Company. The Company also has no express or implied knowledge of any particular purpose for which the product is required and any such information given will not be taken into account in the supply of this product. No responsibility or liability by the Company will be accepted for misuse, misreading or derivation from recommended guidelines in respect of this product and the user shall determine the suitability of the product for his intended use and assume all risks and liability in connection therewith. The information contained in our brochure may change at any time without notice. Any use of this product, **Hydrotite**, in any application should be approved as suitable for use/application by the Design Engineer and Project Manager.

Effective Date: 05 APRIL 2022

CORKJOINT (MALAYSIA) SDN BHD 383102-H

📍 No. 51, Jalan BRP 8/2, Bukit Rahman Putra Industrial Park, 47000 Sungai Buloh, Selangor, MALAYSIA

☎ +603 6148 8010

☎ +603 6148 8020

CORKJOINT (SINGAPORE) PTE LTD 200716724-K

📍 No. 10 Buroh Street #02-26 & 27, West Connect Building, SINGAPORE 627564

☎ +65 6455 9331

☎ +65 6455 8535

